

FEATURES

- The preferred pump frame in the two-gun prep conveyor and tunnel car wash industry
- Forged brass manifold with an exclusive lifetime warranty
- Large-capacity, die-cast, anodized aluminum oil-bath crankcase
- Over-sized connecting rods for maximum life
- Heavy-duty tapered roller bearing.
- Solid ceramic plungers with continuously lubricated packings
- Unitized stainless steel inlet and discharge valves
- Available in left-handed “L” version



SPECIFICATIONS

Pump Model	CW1012	
Maximum Volume	12.0 GPM	10.0 GPM
Maximum Discharge Pressure	1000 PSI	1200 PSI
Maximum Pump Speed	900 RPM	750 RPM
Maximum Inlet Vacuum	2 ft. water (1.8 in. Hg)	
Bore	1.18 in. / 30 mm	
Stroke	.946 in. / 24 mm	
Crankcase Oil Capacity	50.7 oz.	
Maximum Fluid Temperature	165°F	
Inlet Port Thread	3/4-14 BSPP-F	
Discharge Port Thread	3/8-19 BSPP-F	
Shaft Diameter.	1.378 in. / 35 mm	
Weight	45 lbs.	
Dimensions	13.0 x 11.9 x 7.3 in.	

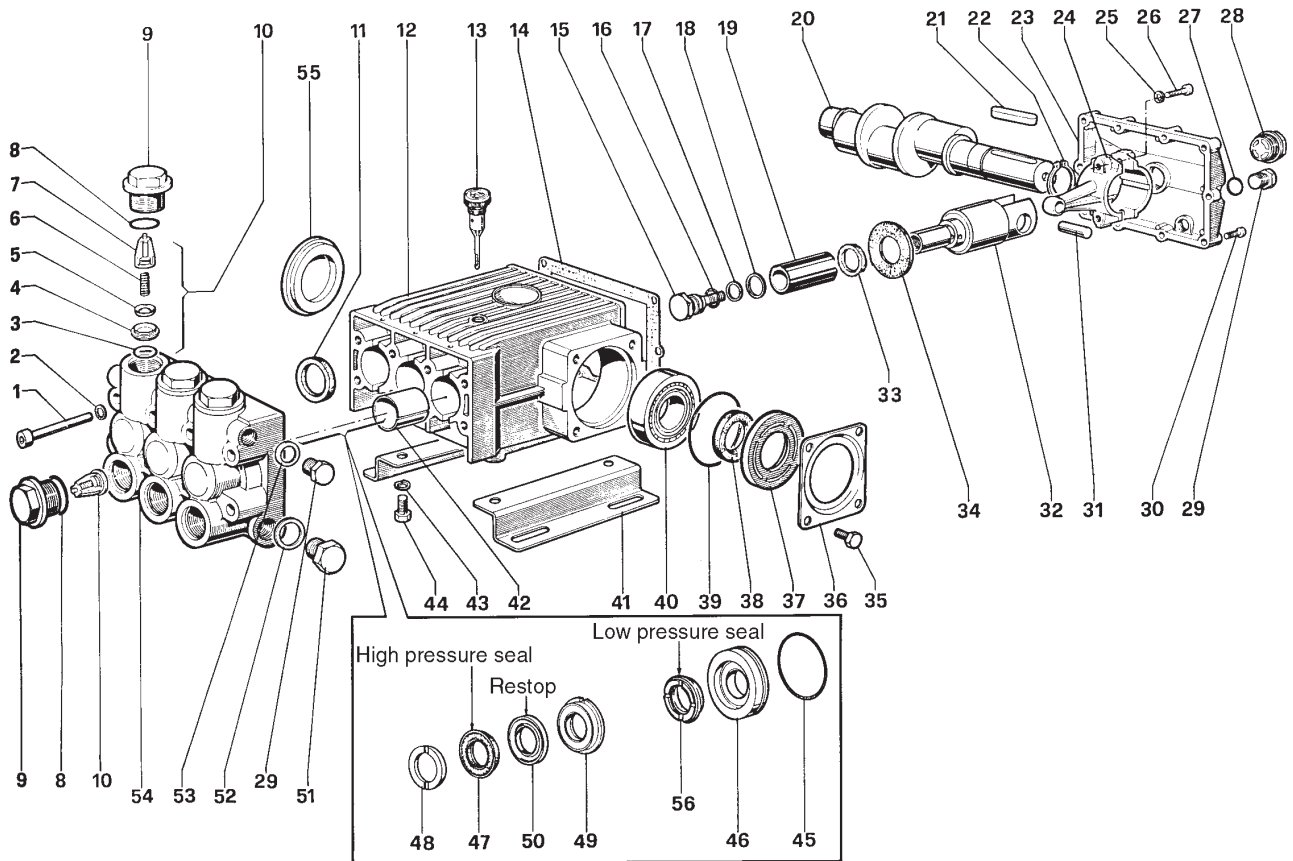

PARTS LIST

ITEM	PART NO.	DESCRIPTION	KIT NO.	QTY.	ITEM	PART NO.	DESCRIPTION	KIT NO.	QTY.	ITEM	PART NO.	DESCRIPTION	KIT NO.	QTY.
1.	99380100	Screw		8	19.	69040109	Plunger (30 mm)		3	38.	90167200	Ring	32	1
2.	96710400	Washer		8	20.	69020535	Crankshaft		1	39.	90413100	O-Ring		2
3.	90385900	O-Ring	62	6	21.	91496900	Key		1	40.	91848100	Bearing		2
4.	36201766	Valve Seat	62	6	22.	90069500	Cir-Clip		1	41.	47200074	Foot		2
5.	36201876	Valve	62	6	23.	69160022	Crankcase Cover		1	42.	90916200	Bushing		3
6.	94739400	Spring	62	6	24.	69030301	Connecting Rod			43.	96710600	Washer		4
7.	36200851	Valve Guide	62	6	25.	96701400	Washer		6	44.	99364400	Screw		4
8.	90405100	O-Ring		6	26.	99309900	Screw		6	45.	90388500	O-Ring	64,67	3
9.	98231200	Cap		6	27.	90383300	O-Ring		1	46.	69080070	Packing Retainer	64,67	3
10.	36706001	Valve Unit	62	6	28.	97596800	Indicator		1	47.	90277000	Packing	67,113	3
11.	90165600	Seal	37	3	29.	98210000	Cap		2	48.	69100051	Head Ring	65,67	3
12.	69010022	Cover		1	30.	99186700	Screw		9	49.	69216770	Intermediate Ring	66,67	3
13.	98210600	Oil Dipstick		1	31.	97739800	Plunger Pin		3	50.	90277400	Ring	113	3
14.	69211984	Gasket		1	32.	69050354	Plunger Guide		3	51.	98226500	Cap		1
15.	69219566	Plunger Bolt	74	3	33.	69211470	Spacer		1	52.	96770000	Washer		1
16.	90384100	O-Ring	74	3	34.	96756500	Slinger		3	53.	96738000	Washer		1
17.	90510700	Anti-Ext. Ring	74	3	35.	99363600	Screw		8	54.	69120741	Manifold		1
18.	96755500	Washer	74	3	36.	68150074	Crankcase Cover		2	55.	69211651	Spacer		1
					37.	69211551	Spacer		1	56.	90277600	Seal, Low Press., 30mm	67,113	3

REPAIR KITS

KIT NO.	32	37	62	64	65	67	74	113
ITEM NO.s INCLUDED IN KIT	38	11	3, 4, 5, 6, 7 (10)	45, 46	48	45, 46, 47, 48, 49, 56	15, 16, 17, 18	47, 50, 56
NUMBER OF ASSEMBLIES IN KIT	2	3	6	3	3	1	3	3
NUMBER OF CYLINDERS KIT WILL SERVICE	2	3	3	3	3	1	3	3

TORQUE SPECS*

Position	Ft.-lbs.
1	29.4
9	73.7
15	14.7
26	14.7
28	13.2
29	29.4
30	7.3
35	29.4
44	29.4
51	51.5